





WHO IS FSILON

YE 19 YEARS

PROFESSIONAL ENGINEERING MATERIAL
SUPPLIER FOR 19 YEARS



- A-share listed company
- Drafting unit for industry standard of integrated ceiling for construction
- Three Industry patents invention recipients
- Professional light source testing centers
- Leading material supplier
- Chairman unit of the Suspended Ceiling Special Committee of China Building Decoration Association
- Top 10 Leading Brands of Integrated Ceiling in China
- High technology enterprises

SENIOR BRAND
HARDCORE STRENGTH



HOME FURNISHING
INDUSTRIAL PARK

260,000m²

HOME FURNISHING
INDUSTRIAL PARK

FSILON Home Building Materials Co., Ltd. was founded in 2005, headquartered in Haiyan, Jiaxing, Zhejiang. We specialize in becoming a large-scale integrated supplier of prefabricated ceiling and wall products, and have a comprehensive strategic deployment of multiple categories including suspended ceilings, walls, and floors. At present, it has an industrial park base of 260,000 square meters, which helps achieve high production capacity and also promotes FSILON to a leading position in intelligent manufacturing in the Chinese market. FSILON has a rich product line and is one of the enterprises with the most complete range of products in the industry. Multi point driven steady growth, continuously setting a benchmark for the industry. On August 3, 2020, it was listed on the A-share of the Shanghai Stock Exchange.

THE TEST REPORT



Type:Utility model patent
Code: ZL 2018 2 0672567



Type:Utility model patent
Code:ZL 2016 10078197.X



Type:Utility model patent
Code: ZL 2018 2 0680433.X



Type:Utility model patent
Code:ZL 2018 2 0216448.0



Type:Design Patent
Code:ZL 2018 3 0160744.9



Type:Design Patent
Code:ZL 2018 3 0161029.7



Type:Design Patent
Code: ZL 2018 3 0160743.4



Type:Design Patent
Code:ZL 2018 3 0161027.8



Type:Design Patent
Code:ZL 2018 3 0194550.0



Type:Design Patent
Code:ZL 2018 3 0194531.8



Type:Design Patent
Code: ZL 2018 3 0194383.X



Type:Design Patent
Code:ZL 2018 3 0194561.9



Type:Design Patent
Code:ZL 2018 3 0194369.X



Type:Design Patent
Code:ZL 2018 3 0194508.9



Type:Design Patent
Code:ZL 2018 3 0194304.5



Type:Design Patent
Code:ZL 2018 3 0194370.2

PREMIUM PRODUCTS

Define industry-leading standards and forge a quality FSILON



Report NO.DX20191989



Report NO.DX20200932



Report NO.DX20200803



Report NO.DX20200235



Report NO.DX20201153



Report NO.DX20200936



Report NO.WTN-0813



Report NO.DX20200236



Report NO.DX20202210



Report NO.DX20200621



Report NO.DX20200738



Report NO.DX20201149

HOSPITAL DECORATION PROJECT



Linzhou second hospital



Heze Traditional Chinese Medicine Hospital



Jiangsu Affiliated University Hospital



Linhai First Hospital



Peking Union Medical College Hospital



Wenzhou Medical College

SCHOOL DECORATION PROJECT



Lanzhou Technology and Business College



Beijing Normal University Dalian Campus



Tongxiang Experimental School



Pingxiang newcity School



Hunan University Of Technology and Business

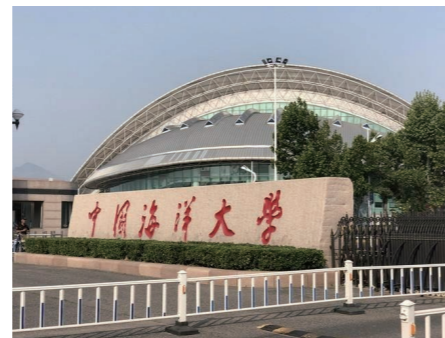

Fushan Campus of Ocean University of China

REAL ESTATE PROJECT



Greentown Foshan Yangliu County



Cangzhou Poly Lafite Mansion

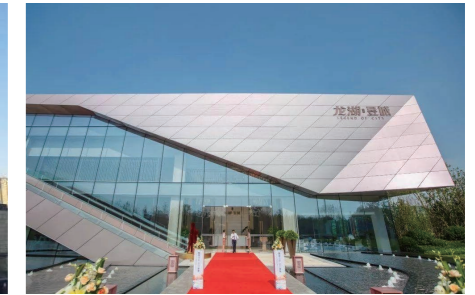

Qingdao Longhu City

REAL ESTATE PROJECT



Shenyang IKEA

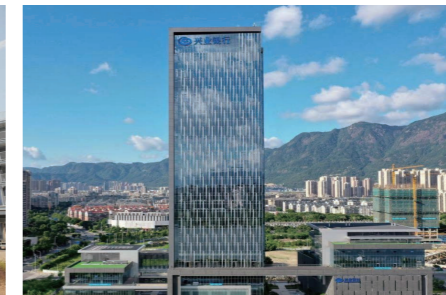

Industry bank building



Xuzhou Hilton

REAL ESTATE PROJECT



Luzhou police office building



Gansu Jingning conservancy bureau



Beijing Shunyi District Transportation Bureau

REAL ESTATE PROJECT



Harbin Metro Line 2



Qingdao Asian Cup Football Stadium

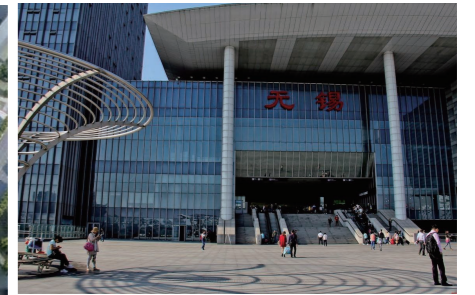

Wuxi Railway Station

CONTENTS

01 INTRODUCTION TO THE FOUR MAIN MATERIALS PRODUCTS

SPC FLOORING	02
WPC WALL PANEL	04
METAL COMPOSITE PANEL	07
ALUMINUM HONEYCOMB PANEL.....	10

02 SUPPORTING INSTALLATION TOOLS AND USAGE METHODS

TYPES OF TOOLS AND USAGE STANDARDS	13
--	----

INTRODUCTION TO
THE FOUR MAIN MATERIALS PRODUCTS

SPC FLOORING

The main raw materials are natural stone powder (heavy calcium carbonate), PVC resin, and auxiliary materials such as plasticizers and stabilizers are added. Made through processes such as rolling, hot pressing, and extrusion, it can be used for lamination, carving and slotting processes, with a variety of colors and shapes.

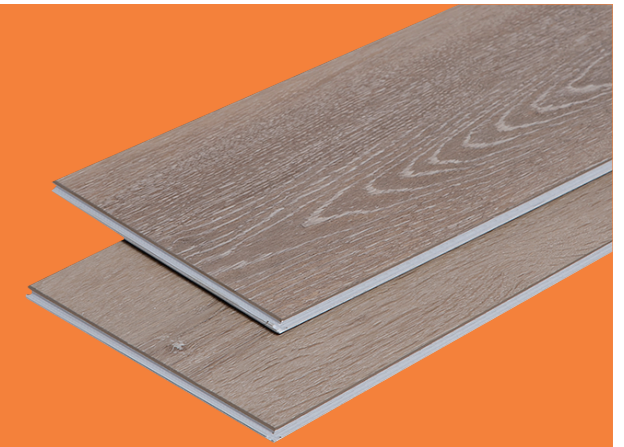

01

INTRODUCTION TO THE FOUR MAIN MATERIALS PRODUCT

PRODUCT LAYERED DIAGRAM

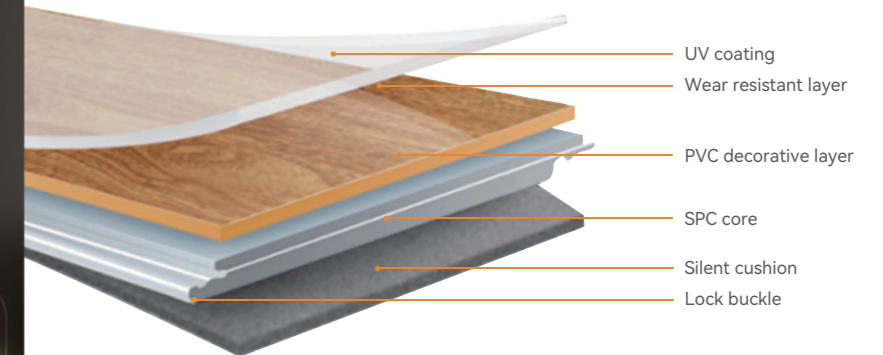

INSTALLATION AND JOIN POINT ILLUSTRATION

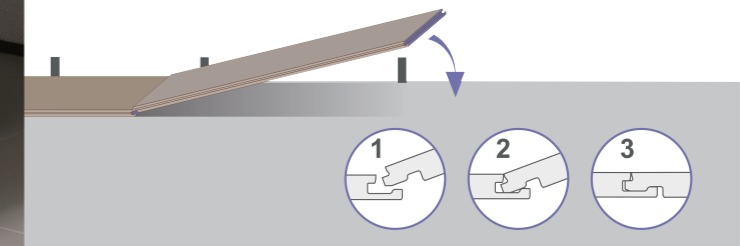

Use a plug-in locking system to splice the short edges, insert the short edges into the female groove of the previous piece at an angle of 15-20 degrees, and the locking buckle will naturally fit after being laid flat on the floor; (Install the short edge first, then the long edge) Install the first row until the last piece, measure and mark it, then use an art knife to cut and break it, and use the cut part of the previous piece to start splicing the next row to stagger the pattern.

BEDROOM

APPLICATION SCENARIOS



Office



Dining room

INTRODUCTION TO
THE FOUR MAIN MATERIALS PRODUCTS

WPC WALL PANEL

 Non toxic and environmentally friendly

 Noise reduction and moisture prevention

 Easy to install

 High appearance presentation

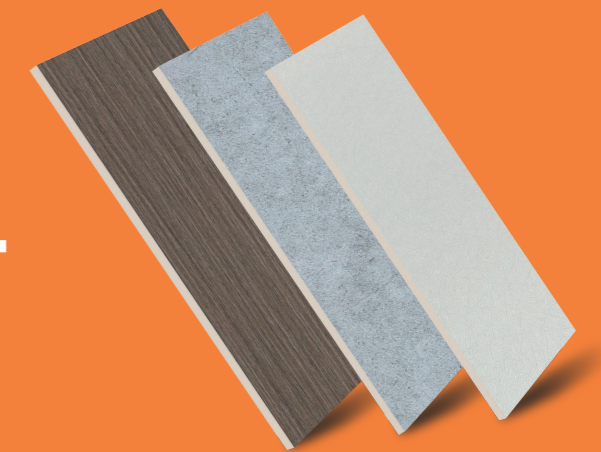

PRODUCT CHARACTERISTICS

Solid WPC wall panel is made of Nature bamboo, wood powder, PVC and other material mixed eco-friendly decoration wall panel . 8mm Hollow core wall panel due to hollow structure . it is good sound insulation, moistureproof, thermal insulation.

PRODUCT LAYERED DIAGRAM

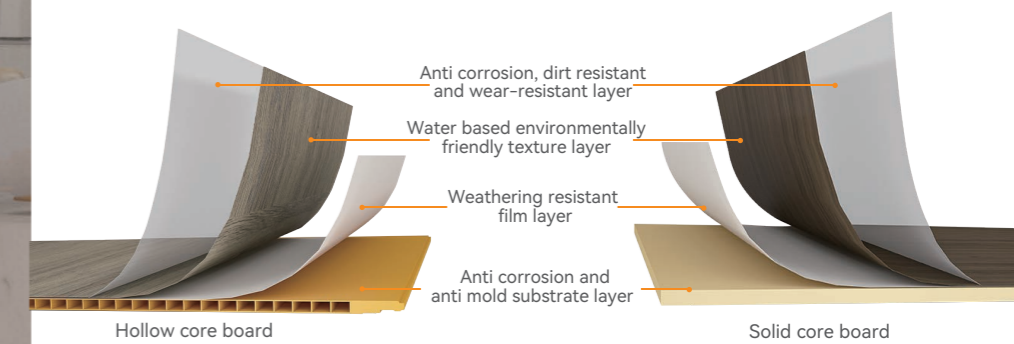

BAKERY

INSTALLATION INSTRUCTION

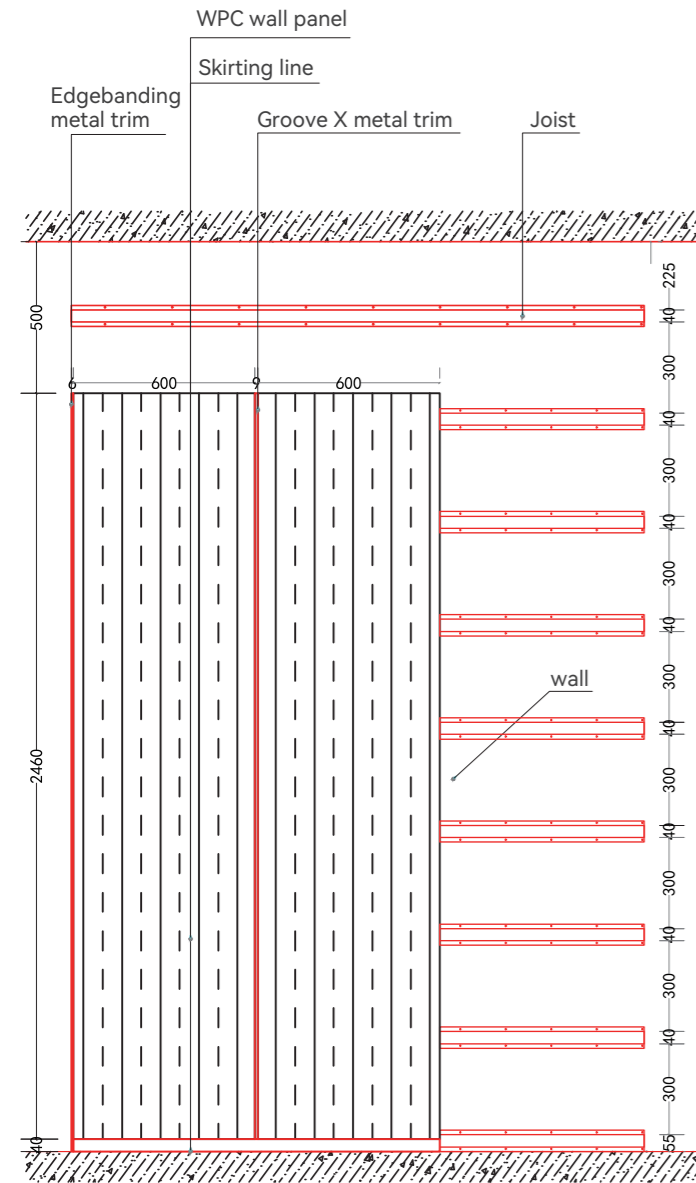

WPC WALL PANEL PERFORMANCE PARAMETER

ITEM	PERFORMANCE REQUIREMENT	
	Solid core	Hollow core
Density(g/cm ³)	0.8~1.1	
Moisture content/%	≤2	≤1.2
Bending strength/Mpa	average≥20	average≥18
	minimum≤15	minimum≤14
Dimensional stability/%	≤0.75	
Shore hardness(HD)	≥55	
Thickness swelling rate/%	≤0.4	≤0.5
Impact oughness at room temperature(KJ/m ²)	≥0.05	
Dent resistance/mm	≤0.5	
Scratch resistance	No more than 90% continuous scratches on the surface, no damage to the pattern	
Peel strength ^a /N	≥40	
VST(°C)	≥78	
Adhesion of coatng ^b / level	≤2	
Surface resistance to contamination	No pollution and no corrosion	
Anti artificial climate aging	CF To Light(grey sample)/grade	≥3
Total volatile organic compounds (TVOC) (72h)	0.01mg/m ² ·h	
Heavy metal content	Soluble Pb	Not detected
	Soluble Cd	Not detected
	Soluble Cr	Not detected
	Soluble Hg	Not detected
Formaldehyde emission	0.05mg/m ³	

a. Suitable for decorative surfaces with film (PVC, PET, PU, wood veneer, etc.)
 b. Suitable for WPC integrated wall panel.

INTRODUCTION TO THE FOUR MAIN MATERIALS PRODUCTS

METAL COMPOSITE PANEL



Eco friendly



Fireproof Easy



Disassembly



Thermal insulation

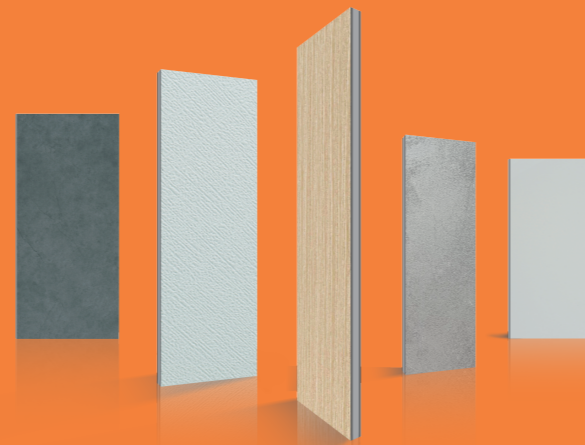

PRODUCT DESCRIPTION

The advantages of A-level Metal composite panels is security, A2 level fire rating and easy installation, dust-free and noiseless during construction.

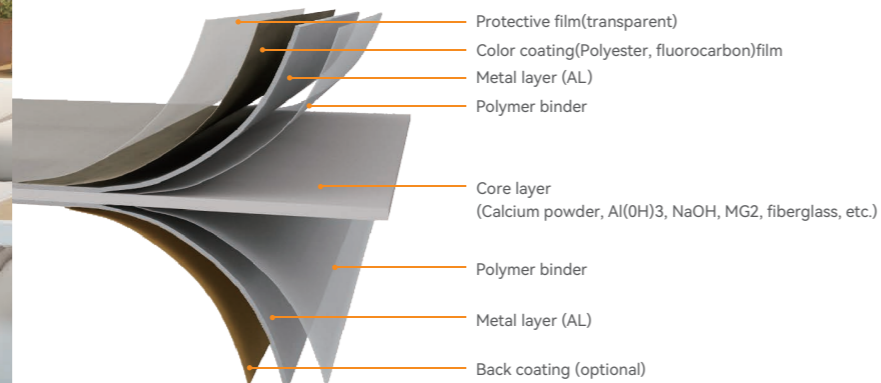

HOSPITAL WARD

INSTALLATION INSTRUCTION

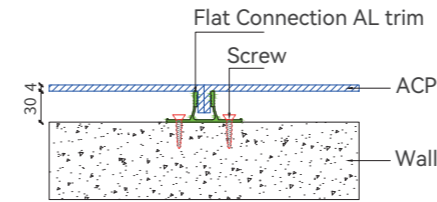

FLAT CONNECTION AL TRIM

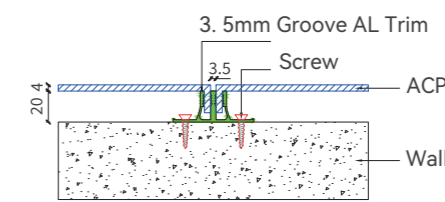

GROOVE AL TRIM

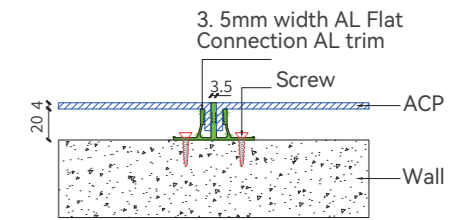

CONNECTION AL TRIM

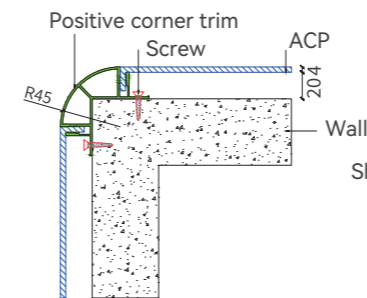

POSITIVE CORNER TRIM

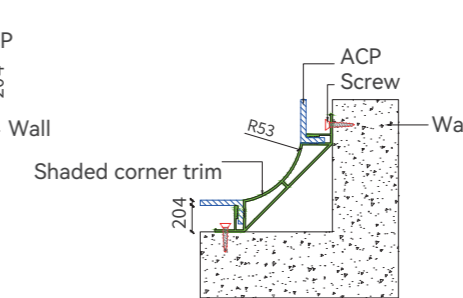

SHADED CORNER TRIM

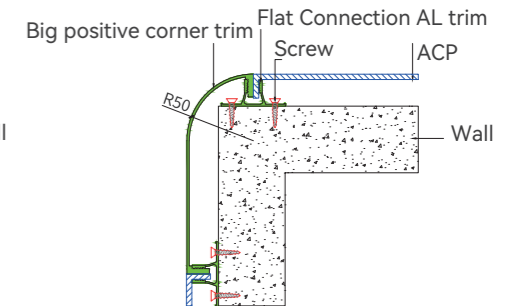

BIG POSITIVE CORNER TRIM

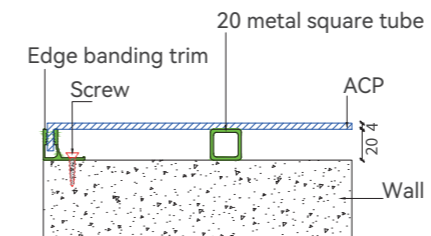

EDGE BANDING TRIM

ALUMIUM COMPOSITE PANELS PERFORMANCE PARAMETER

INSPECTION ITEM	STANDARD REQUEST	RESULT	CONCLUSION	TEST STANDARD	
Main part heat value (AL panel)	$\leq 3.0\text{MJ/kg}$	0MJ/kg	Qualify	GB/T 14402-2007	
Main part heat value (core material)	$\leq 3.0\text{MJ/kg}$	2.1MJ/kg	Qualify		
Internal secondary heat value (polymeric membran)	$\leq 4.0\text{MJ/m}^2$	3.3MJ/m ²	Qualify		
External secondary heat value	$\leq 4.0\text{MJ/m}^2$	1.6MJ/m ²	Qualify		
Total heat value of combustion	$\leq 3.0\text{MJ/kg}$	2.6MJ/kg	Qualify		
Combustion Performance Class A (A2-s1, d0, t0)	Combustion rate growth index (FIGRA _{0.2MJ})	$\leq 120\text{W/s}$	12W/s	Qualify	GB/T 20284-2006
	THR in 600s	$\leq 7.5\text{MJ}$	1.2MJ	Qualify	
	Lateral flame spread	Not reach the experimental long wing edge	Not reach the experimental long wing edge	Qualify	
	Smoke production in 600s	$\leq 50\text{m}^3$	36m ³	Qualify	
	Flue gas formation rate	$\leq 30\text{m}^3/\text{s}^2$	1m ³ /s ²	Qualify	
	Combustion particles	NO Combustion particles IN 600S	NO Combustion particles IN 600S	Qualify	GB/T 20285-2006
	Smoke toxicity	Reach quasi-safety level one	Reach quasi-safety level one	Qualify	
	burning sample installation instructions	Install as required the decoration surface is tested. The backplane of the sample is a calcium silicate plate with a thickness of 12mm and a density of 800kg/m ³ .			

INTRODUCTION TO
THE FOUR MAIN MATERIALS PRODUCTS

ALUMINUM HONEYCOMB PANEL

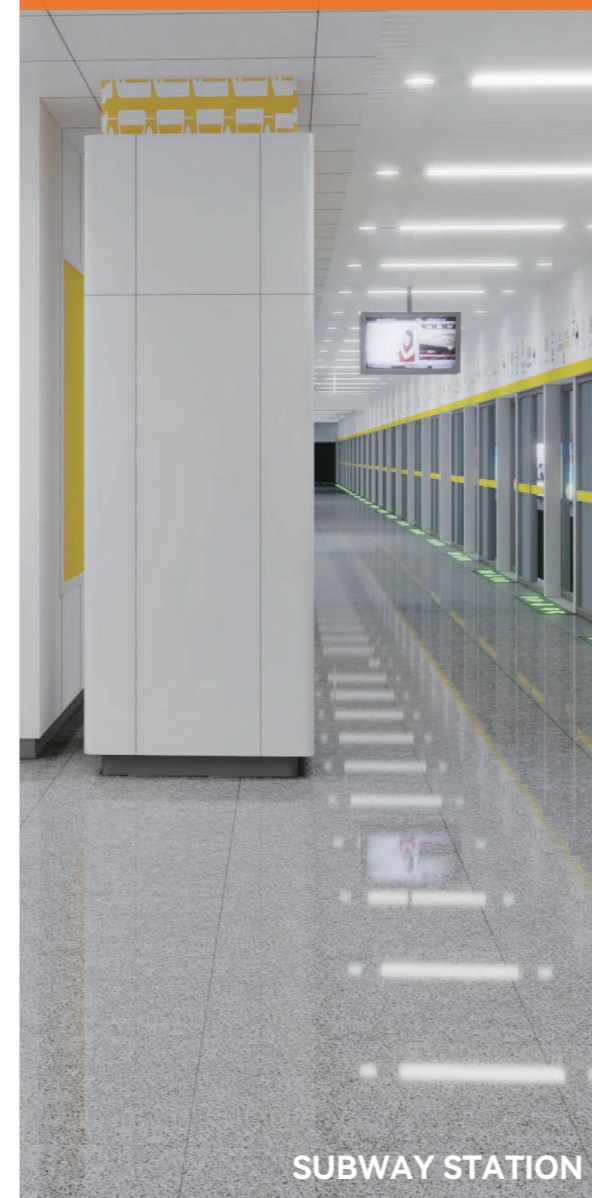
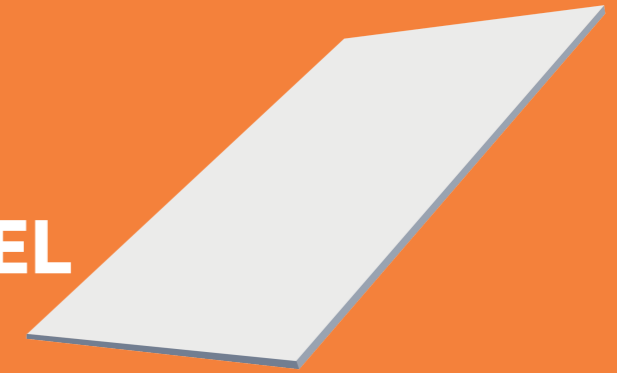

SUBWAY STATION

PRODUCT STRUCTURE

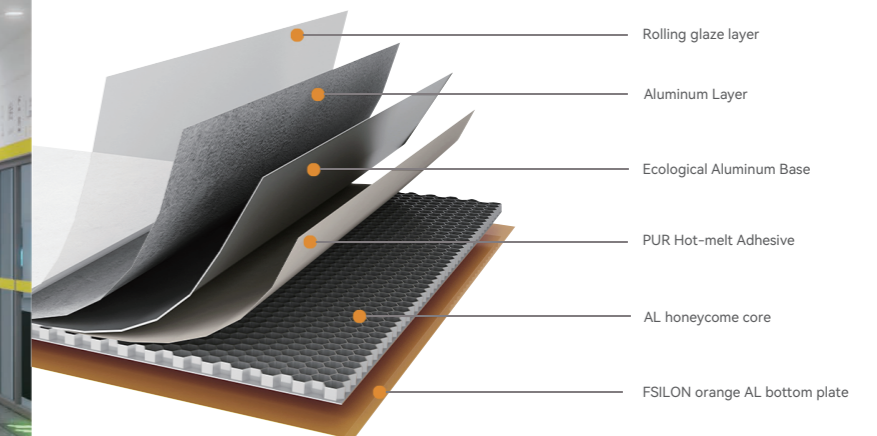

PRODUCT DESCRIPTION

Frameless honeycomb panel is composed by multi layer aluminum coil and aluminum honeycomb core, it is good flatness with micro-seam splicing. Experiment shows that 10mm thickness Frameless honeycomb panel is more sound insulation, heat insulation, impact Home decoration, hotel, chain restaurants, etc resistance, higher flatness and improve the utilization rate of space.

INSTALLATION INSTRUCTION

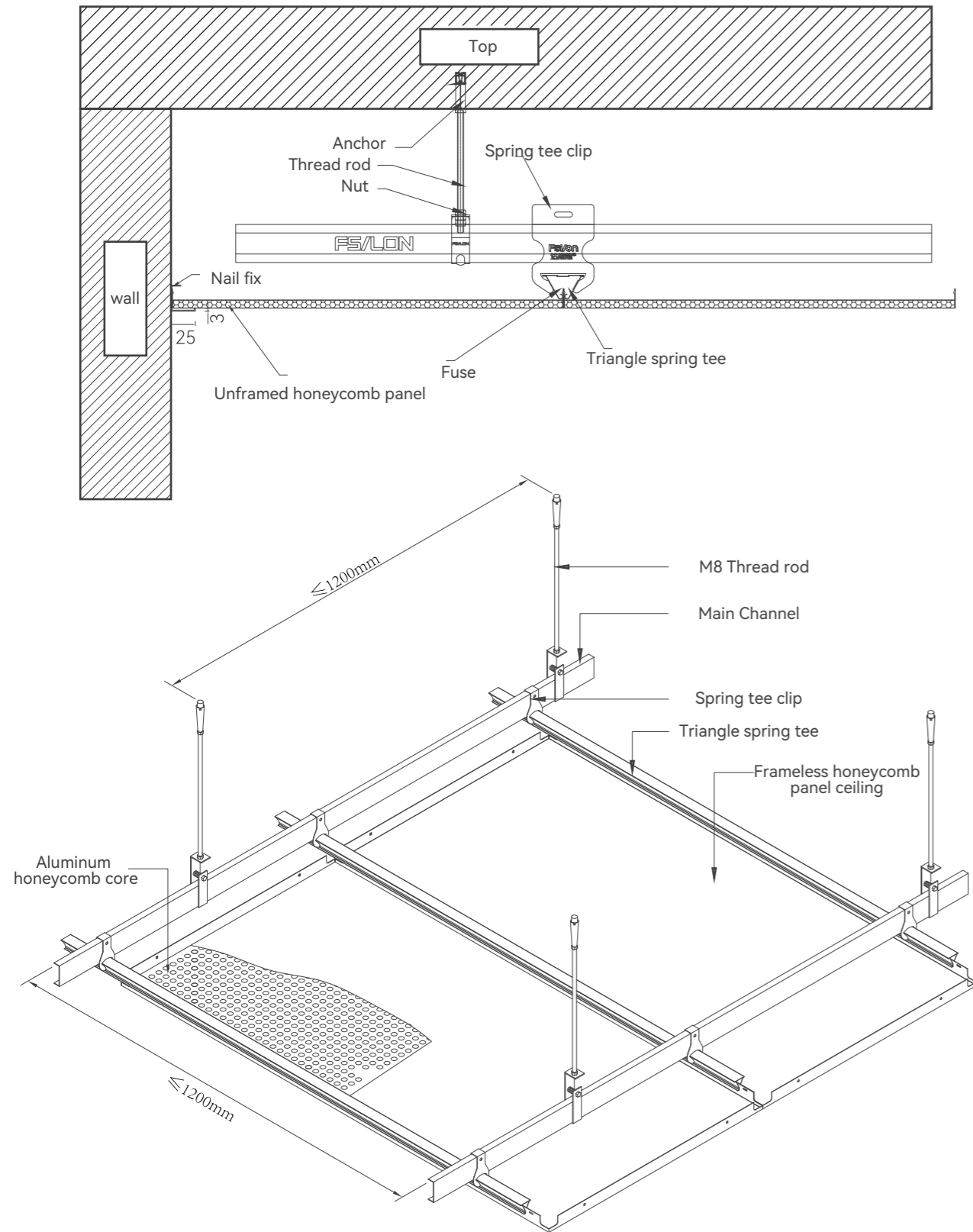

HONEYCOMB PANEL PERFORMANCE PARAMETER

INSPECTION ITEM	STANDARD REQUEST	RESULT	CONCLUSION	TEST STANDARD	
Surface hardness	$\geq \text{HB}$	2H (Zhonghua Pencil)	Qualify	JC/T 2113-2012 7.7.1 GB/T 6739-2006	
Adhesion	Standardizing laboratory	Level 0	Level 0	Qualify	Q/CYCTC 0110-2017 GB/T 17748-2008 7.7.4 GB/T 9286-1998(2004)
Carbonate resistance	No change	No change	Qualify	Q/CYCTC 0110-2017 GB/T 17748-2008 7.7.7	
Alkali resistance	No change	No change	Qualify	Q/CYCTC 0110-2017 GB/T 17748-2008 7.7.8 GB/T 11942-1989	
Flat tensile strength	Average $\geq 0.6\text{Mpa}$ Minimum $\geq 0.4\text{Mpa}$	Average 1.13Mpa Minimum 0.97Mpa	Qualify	JC/T 2113-2012 7.7.13 GB/T 1452-2005	
Flat compression strength	$\geq 0.6\text{Mpa}$	1.07Mpa	Qualify	JC/T 2113-2012 7.7.13 GB/T 1455-2005	
Flat elastic modulus	$\geq 25\text{Mpa}$	45.3Mpa	Qualify	JC/T 2113-2012 7.7.14 GB/T 1455-2005	
IPSS	$\geq 0.4\text{Mpa}$	0.54Mpa	Qualify	JC/T 2113-2012 7.7.14 GB/T 1455-2005	
Plane shear elastic modulus	$\geq 3.0\text{Mpa}$	3.73Mpa	Qualify	JC/T 2113-2012 7.7.15 GB/T 1456-2005	
Shear stiffness	$\geq 1.0 \times 10^4 \text{N}$	$3.53 \times 10^4 \text{N}$	Qualify	JC/T 2113-2012 7.7.15 GB/T 1456-2005	
Formaldehyde emission (climate chamber method)	$E1 \leq 0.124\text{mg/m}^3$	0.05mg/m^3	Qualify	GB 18580-2017 5 GB/T 17657-2013 4.60	

02

TYPES OF TOOLS USAGE SPECIFICATIONS

01 CUT-OFF MACHINE

USING STANDARDS

- ① Cut off profile lines, wooden strips, etc
- ② Cut the line at a 45 degree angle



USAGE METHOD



Install blades, which can be replaced according to different cutting needs. Normal use of 120 foot saw aluminum blade

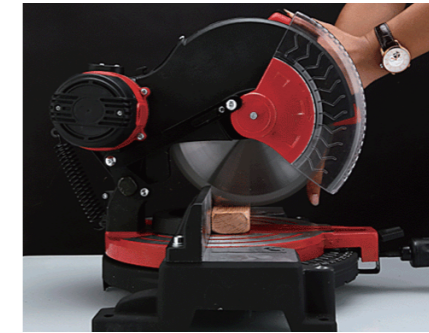

When cutting, hold the switch tightly with one hand and press the machine downwards, while holding the material to be cut with the other hand



Rotate the machine, adjust the angle to be cut, and cut normally at a 45 degree angle

02 TAPE MEASURE

USING STANDARDS

- ① Measure wall dimensions
- ② Assists in drawing lines as a ruler
- ③ Measuring wall panels



USAGE METHOD



Hook one end of the wall panel and pull the tape measure



Straighten and measure wall dimensions with both hands



Pull a tape measure against the wall to measure the size of the wall

03 RANGE FINDER

USING STANDARDS

- ① Place it flat on the wall
- ② Adjust the machine measurement starting from the bottom
- ③ Do not move before data is available



USAGE METHOD



Place it flat on the wall data is available



Adjust the machine measurement starting from the bottom



Do not move before data is available

04 GRADIENTER

USING STANDARDS

- ① Flat placement
- ② Turn on the switch
- ③ Adjusting height



USAGE METHOD



It needs to be placed flat and reach the level without any warning sound

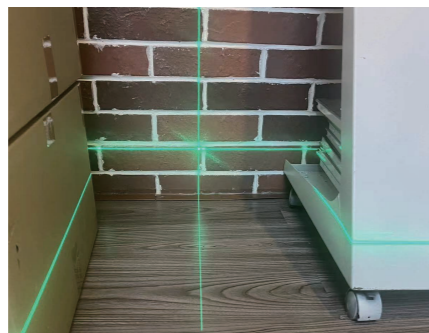

Adjust horizontal or vertical lines as needed



Adjust the height of the spirit level using a bracket according to the actual situation

05 BOARD CUTTER

USING STANDARDS

- ① Confirm cutting position
- ② Fixed machine
- ③ Uniform cutting speed



USAGE METHOD



Press against one end of the wall panel, confirm the cutting position, and fix the cutting machine

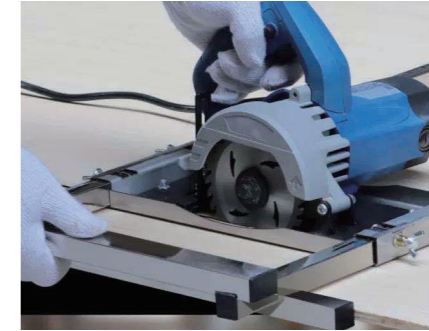

Hold the cutting machine with one hand while holding down the power supply, and hold the support plate with the other hand



Gently push the cutting machine with uniform force and speed, pay attention to hand safety

06 PNEUMATIC NAIL GUN

USING STANDARDS

- ① Air pump connection
- ② Insert the gun nail
- ③ Align and nail



USAGE METHOD



Insert appropriate sized straight nails according to the actual situation



Connect the air pump and air nail gun



Aim the gun head at the position where the nail is to be nailed and then pull the trigger

07 EDGE TRIMMER

USING STANDARDS

- ① Grasp tightly with both hands to start the machine
- ② Align the cutting position
- ③ Pay attention to eye protection during cutting



USAGE METHOD



Turn off the fixing screw, insert a suitable cutting piece, and fix the screw



When starting the machine, it is necessary to hold it tightly with both hands to prevent vibration



Hand and eye protection is required when cutting objects

09 INK FOUNTAIN

USING STANDARDS

- ① fill in ink
- ② find right place
- ③ pull the string



USAGE METHOD



Open the ink cartridge and put in an appropriate amount of ink



Hold down the valve while pulling the line to allow the line to absorb ink

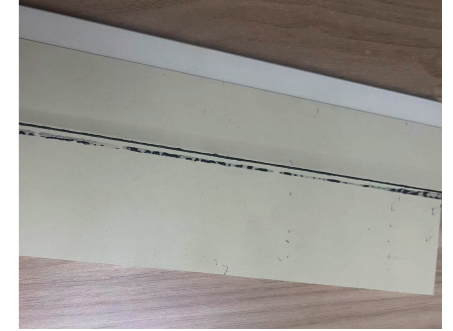

Straighten the ink line and forcefully snap the line to leave ink marks on the wall

08 SLOTTER

USING STANDARDS

- ① Adjusting the blade height
- ② Confirm the slot cutting position
- ③ Fixed baffle



USAGE METHOD

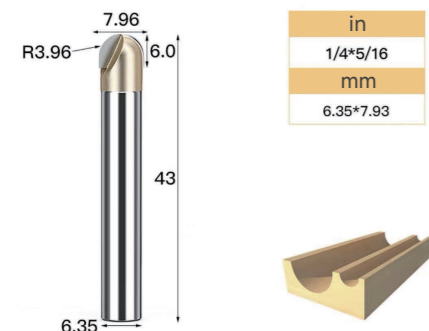

Install the blade and select the large arc blade



Adjust the position of the blade and cut it to a position 1mm away from the film



Fix with a baffle on one side to ensure that the milling groove position is not offset, and hold tightly with both hands to push the milling groove machine

10 SILENT AIR PUMP

USING STANDARDS

- ① Install air filter
- ② Insert power and wait for inflation to complete
- ③ Connect the air nail gun and replace it by holding down the connection interface



USAGE METHOD



Install air filters to prevent dust from entering and effectively reduce noise



Install the interface on the air release valve to connect the leather tube



After inflation is complete, connect one end of the hose to the air pump and the other end to the air gun

11 WOODWORKING PLANER

USING STANDARDS

- ①Grab the handle of the plane
- ②Slightly push the plane
- ③Pay attention to the position of your hands



USAGE METHOD



Adjust the blade to extend a little, basically level with the base



Take out the upper part of the wooden planer with one hand and stabilize the wall panel with the other hand. Pay attention to hand safety



Slight force sliding, uniform speed, only suitable for minor adjustments

12 TOP LIFTER

USING STANDARDS

- ①Insert bottom of wall panel
- ②Press the handle to lift the wall panel
- ③Remove after fixing the wall panel



USAGE METHOD



Insert the top lifter into the bottom of the board



Push the handle up to lift the wall panel, and wait for it to be fixed before removing it



Multiple height lifters need to be placed, one for a distance of about 30 centimeters

13 POLYURETHANE FOAM

USING STANDARDS

- ①Shake the can body for 1 minute before use
- ②Installing the spray head
- ③Two-thirds of the spray filling area



USAGE METHOD



Shake the can body up and down for 1 minute before use



Insert the hose nozzle



Two-thirds of the spray filling area is sufficient

14 SUPER ADHESIVE

USING STANDARDS

- ① Spot gluing
- ②Gently tap with a leather hammer
- ③Remove the support after solidification



USAGE METHOD



Cut the rubber bottle and install the rubber nozzle
Install the glue gun and press the handle of the glue gun

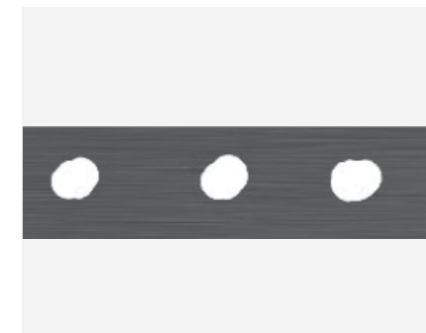

Spot glue, with a spacing of about 20 centimeters

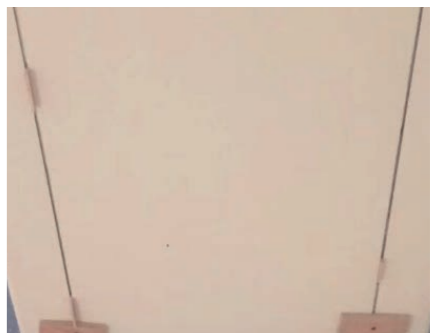

Wall panels need to be fixed and removed after 24 hours of adhesive curing

15 ELECTRIC HAND DRILL

USING STANDARDS

- ①Install drill bit
- ②Insert power supply
- ③Adjust the rotation direction of the drill bit



USAGE METHOD



Insert a suitable drill bit power supply according to actual needs



Ensure that the battery is sufficient and hold the handle tightly with one hand



Adjust the rotation direction before starting

16 RUBBER HAMMER

USING STANDARDS

- ①Appropriate strength
- ②Find the right tapping position
- ③Grasp the handle tightly with onehand and be careful to strike your hand



USAGE METHOD



Choose a hammer of appropriate size Recommended 400g/120z



Find the right tapping position The edges and middle of the wall panel need to be tapped



Grasp the end of the handle tightly, apply force evenly, and pay attention to hand protection

17 CUTTER KNIFE

USING STANDARDS

- ①Blade extends 3 centimeters
- ②Proper intensity of movement
- ③Pay attention to blade breakage



USAGE METHOD



Install the blade so that it protrudes about 3cm



When the blade is not sharp, the blade can be crushed and then extended



Slide the art knife evenly and be careful not to break the blade

18 NAIL GUN

USING STANDARDS

- ①Air pump connection
- ②Insert the gun nail
- ③Align the nails and press down firmly on the base



USAGE METHOD

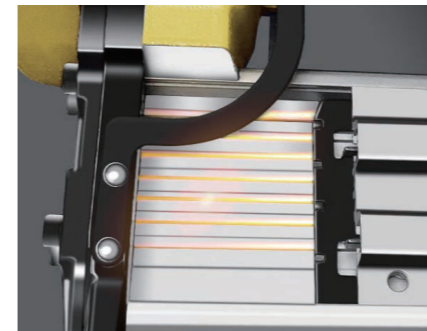

Open the nail box and place steel nails of appropriate size



Connect air pump and steel nail gun



To avoid the steel nails from not being inserted firmly,use your hands to firmly press down on the base

19 CUT-OFF MACHINE

USING STANDARDS

- ①Make sure the battery is fully charged
- ②Protect yourself and hold the handheld saw tightly with one hand

- ③Cut along the positioning direction



USAGE METHOD



View the battery capacity and install the battery



When the button is pressed, the hand saw begins to work



Cut along the positioning direction

20 IMPACT DRILL

USING STANDARDS

- ①Install the drill bit
- ②Set the speed and torque
- ③Aim at the drilling position



USAGE METHOD



Adjusting the speed and torque of the impact drill



Application of impact drill



Determine the drilling or tightening position of the impact drill